

Class II Microbiological safety cabinet, 900 mm wide

CONFORMIDAD

EN 12469

ADVANTAGES

- Convenient for micro-organisms
- Low noise fan
- High intensity of light
- White walls for a glare-free brightness
- Smooth walls, rounded corners and no welds ; allowing easy cleaning and decontamination
- Easy replacement of the filters
- Ergonomic armrest for long periods of handling
- Electronic compartment located outside the contaminated area
- Alarms for : power failure, control system failure, open window, low and high airflow velocity, filters clogged

SINO TAMBIÉN...

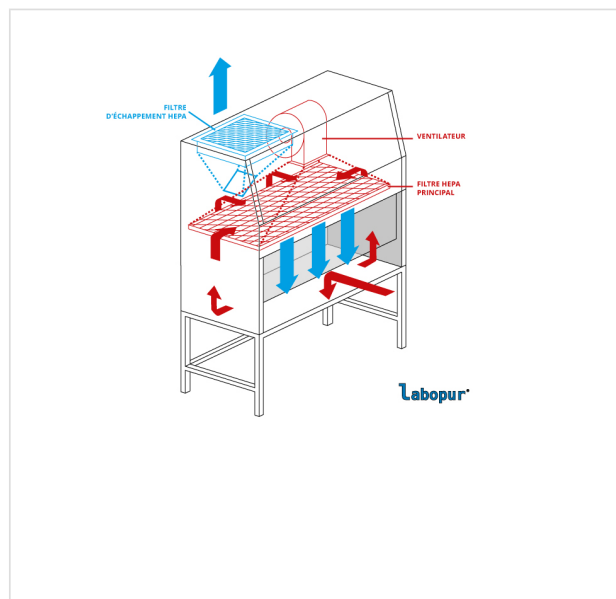

CARACTERISTICAS TECNICAS

Modelo	PSM9	Tensión (voltios)	0.99999
Conformidad	EN 12469	Potencia eléctrica (vatios)	1860
Velocidad del aire (m/s)	0,4	Código Aduanero	84146011
Tensión (voltios)	220		

PRODUITS COMPLÉMENTAIRES

- Front enclosure with UV light for PSM9 (Réf : FACPSM09)
- Support stand for FLV09 and PSM9 (Réf : TH09)
- Gas valve with solenoid valve (Réf : VANGAZ)
- Vacuum valve (Réf : VANVID)

Modelo	Dimensiones exteriores alt x anc x pro (mm)	Dimensiones interiores alt x anc x pro (mm)	Peso (kg)
PSM9	1390 x 1050 x 790	630 x 885 x 630	144.00